

UNIVERSAL 500 L

TECHNICAL SPECIFICATION SHEET:

PATENT APPLIED

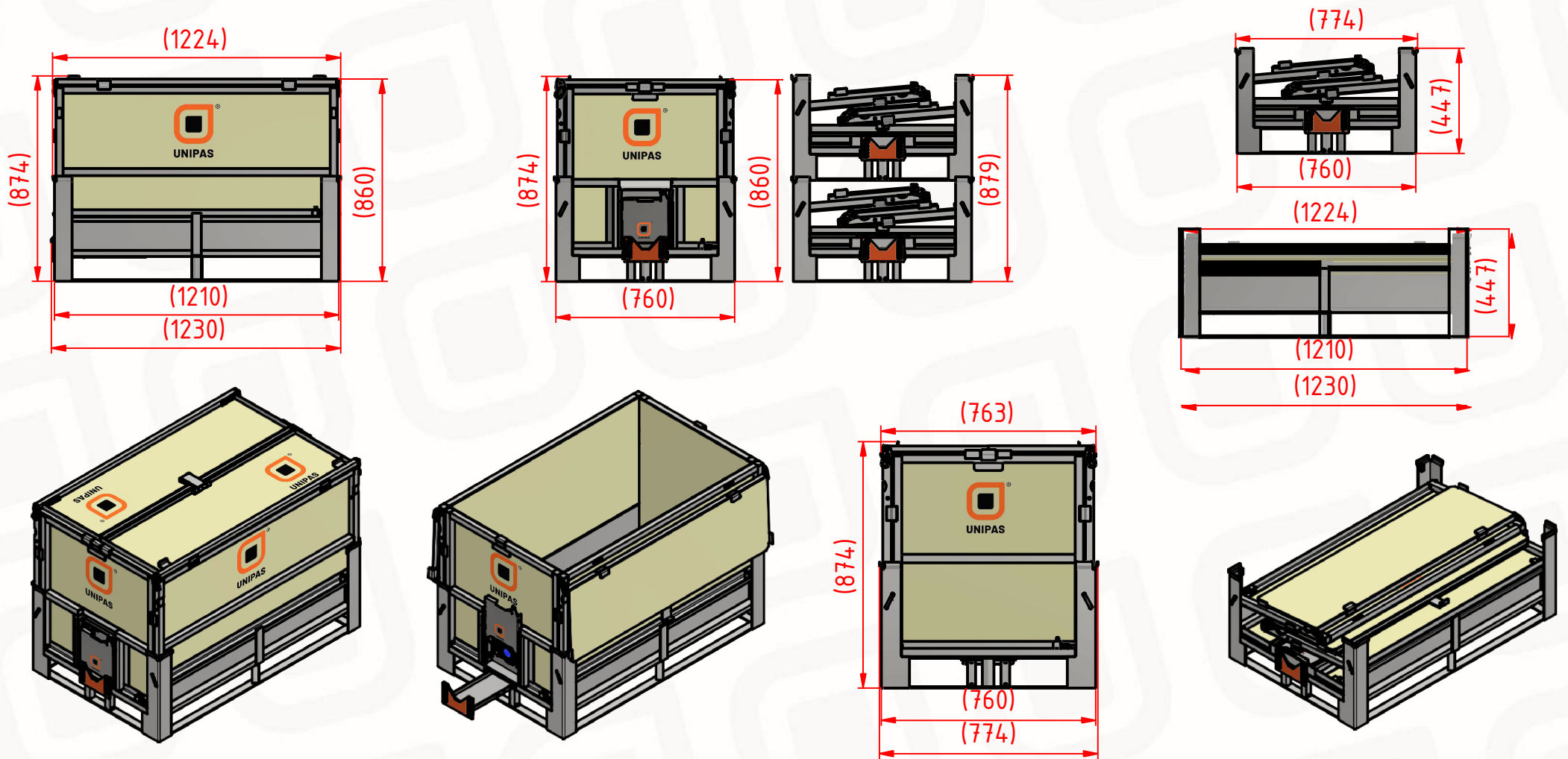

| DESCRIPTION: | | FOLDABLE GALVANIZED STEEL IBC WITH POLYPROPYLENE BOARDS FOR LIQUID MATERIAL | |
|----------------------|---------------------------------------|---|-------------------------------|
| EXTERNAL DIMENSIONS: | (W760xL1210xH859mm) | MAX DYNAMIC FULL LOAD UNITS 2PCS | MAX DYNAMIC FOLDED UNITS 6PCS |
| INTERNAL DIMENSIONS: | (W676xL1128xH693mm) | WEIGHT: 1807 kg | HEIGHT: 2607 mm |
| FOLDING HEIGHT: | (447 mm) | MAX STATIC FULL LOAD UNITS 6PCS | MAX STATIC FOLDED UNITS 12PCS |
| LID STACKING HEIGHT: | (860mm)/(874mm) | WEIGHT: 5400 kg | HEIGHT: 5199 mm |
| EMPTY WEIGHT: | 103,5 kg | | |
| VOLUME: | 527 L | | |
| LOAD CAPACITY: | 800 kg | | |
| DYNAMIC LOAD: | 1807 kg | | |
| STATIC LOAD: | 5400 kg | | |
| RACKING LOAD: | 1807 kg | | |
| FOLDING RATIO | 1:2 | | |
| STANDARD COLORS: | ZINC GRAY/GRAY | 20 GP: | 55 units |
| MATERIAL: | GALVANIZED STEEL+POLYPROPYLENE | 40 GP: | 140 units |
| WORKING TEMPERATURE: | -25+60 °C | 40 HC: | 164 units |
| STANDARD TRAILER: | 204 units | MEGA TRAILER: | 204 units |

DISCLAIMER: Capacity is dependent on the application and environment of use.
 The suitability of application is to be consulted with Unipas.
 Specifications subject to change without further notice.
 All dimensions approximate.

