

**TECHNICAL SPECIFICATION SHEET:**

**MX2 - IBC CONTAINER 1000 L**

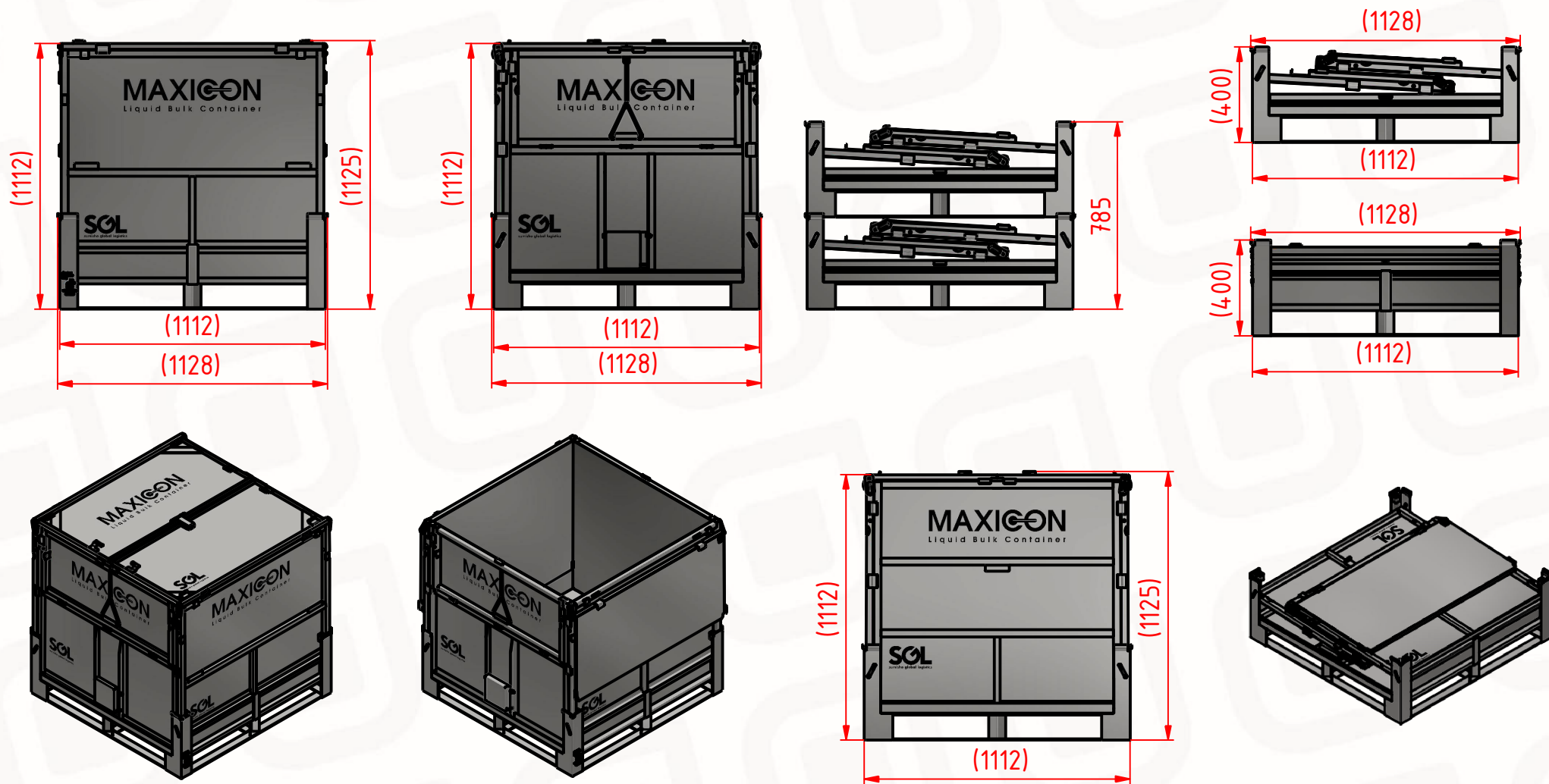
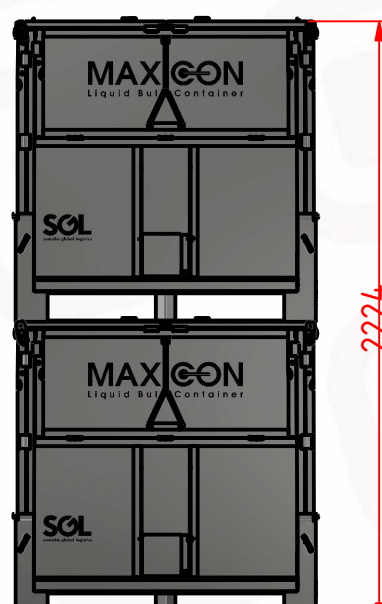
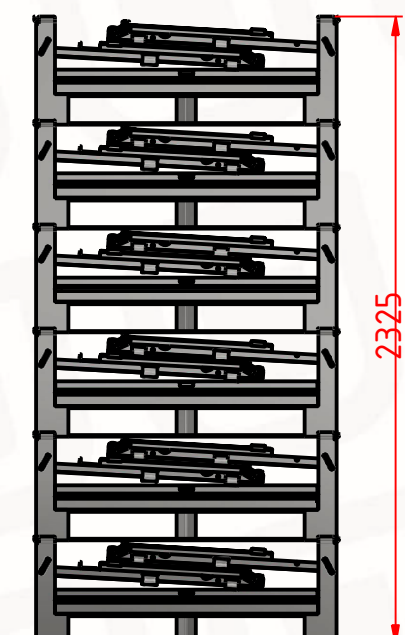

DESCRIPTION:		FOLDABLE STAINLESS STEEL IBC WITH FOR LIQUID MATERIAL	
EXTERNAL DIMENSIONS:	(W1112xL1112xH1112mm)	MAX DYNAMIC FULL LOAD UNITS 2PCS	MAX DYNAMIC FOLDED UNITS 6PCS
INTERNAL DIMENSIONS:	(W1035xL1035xH952mm)	WEIGHT: <b>3083 kg</b>	HEIGHT: <b>2325 mm</b>
FOLDING HEIGHT:	(400mm)	MAX STATIC FULL LOAD UNITS 5PCS	MAX STATIC FOLDED UNITS 12PCS
LID STACKING HEIGHT:	(1112mm) / (1125mm)	WEIGHT: <b>7707 kg</b>	HEIGHT: <b>4635 mm</b>
EMPTY WEIGHT:	<b>141,5 kg</b>		
VOLUME:	<b>1019 L</b>		
LOAD CAPACITY:	<b>1400 kg</b>		
DYNAMIC LOAD:	<b>3083 kg</b>		
STATIC LOAD:	<b>7707 kg</b>		
RACKING LOAD:	<b>3083 kg</b>		
FOLDING RATIO	<b>1:2,5</b>		
STANDARD COLORS:	<b>STAINLESS STEEL</b>	20 GP:	<b>60 units</b>
MATERIAL:	<b>STAINLESS STEEL 1.4301</b>	40 GP:	<b>120 units</b>
WORKING TEMPERATURE:	<b>-25+60°C</b>	40 HC:	<b>120 units</b>
STANDARD TRAILER:	<b>154 units</b>	MEGA TRAILER:	<b>154 units</b>

**DISCLAIMER:** Capacity is dependent on the application and environment of use.  
 The suitability of application is to be consulted with Unipas.  
 Specifications subject to change without further notice.  
 All dimensions approximate.

