

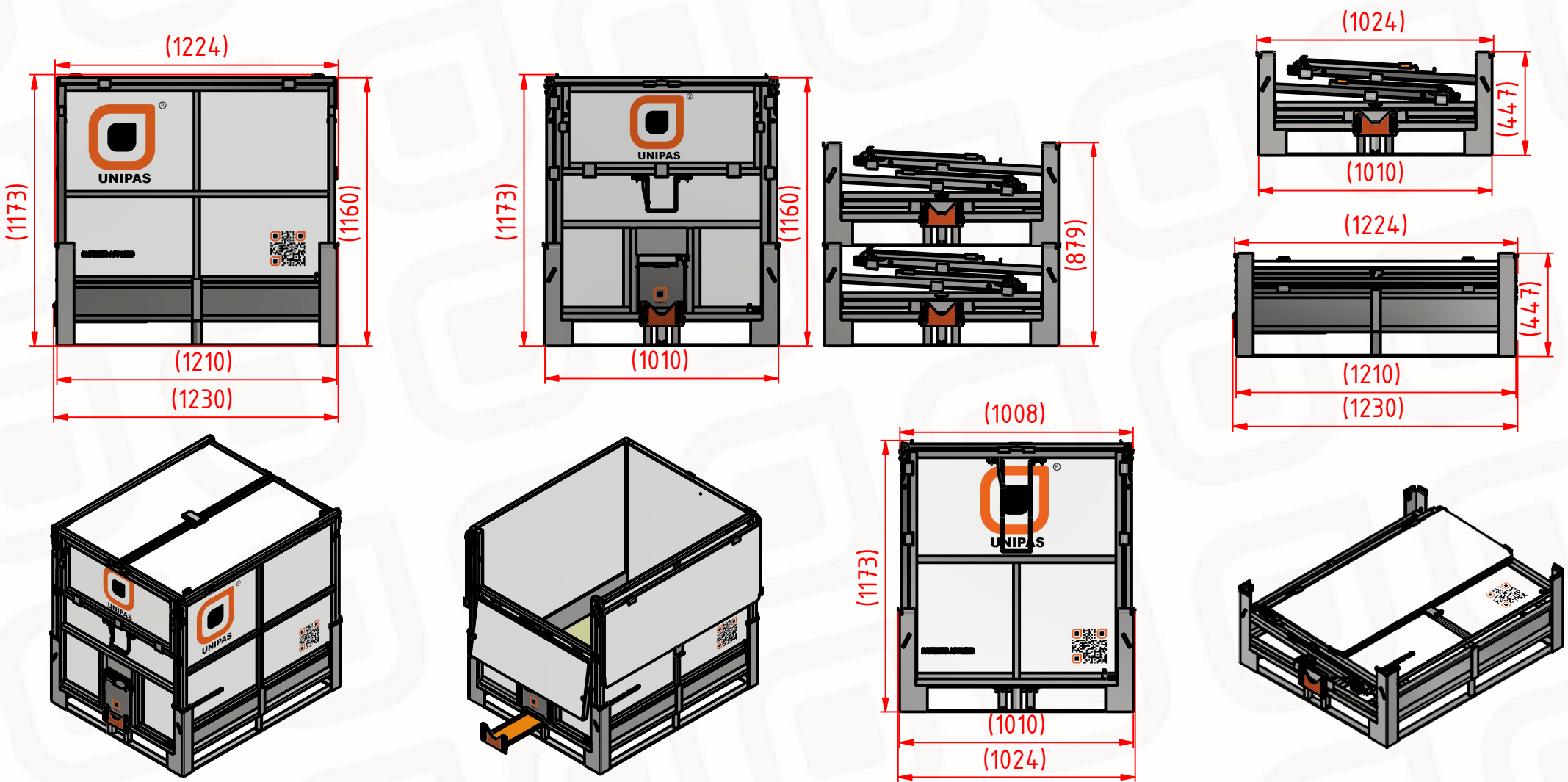

TECHNICAL SPECIFICATION SHEET:

PATENT APPLIED

UNIVERSAL 1000 L

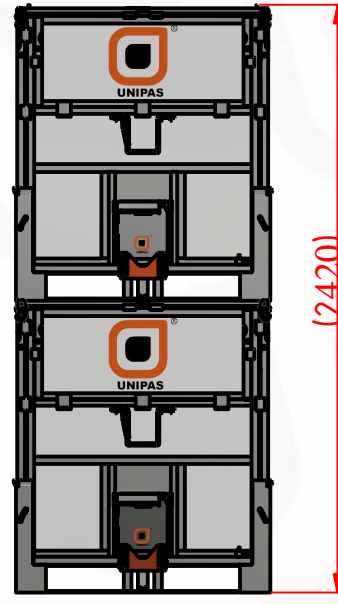

DESCRIPTION:		FOLDABLE GALVANIZED STEEL IBC WITH POLYPROPYLENE BOARDS FOR LIQUID MATERIAL	
EXTERNAL DIMENSIONS:	(W1024xL1230xH1173mm)	MAX DYNAMIC FULL LOAD UNITS 2PCS	MAX DYNAMIC FOLDED UNITS 6PCS
INTERNAL DIMENSIONS:	(W930xL1126xH991mm)	WEIGHT: 3070 kg	HEIGHT: 2612 mm
FOLDING HEIGHT:	(447 mm)	MAX STATIC FULL LOAD UNITS 5PCS	MAX STATIC FOLDED UNITS 12PCS
LID STACKING HEIGHT:	(1160mm) / (1173mm)	WEIGHT: 7675 kg	HEIGHT: 5199 mm
EMPTY WEIGHT:	135 kg		
VOLUME:	1035 L		
LOAD CAPACITY:	1400 kg		
DYNAMIC LOAD:	3070 kg		
STATIC LOAD:	7675 kg		
RACKING LOAD:	3070 kg		
FOLDING RATIO	1:2,5		
STANDARD COLORS:	ZINC GRAY/GRAY		
MATERIAL:	GALVANIZED STEEL+POLYPROPYLENE	40 GP:	100 units
WORKING TEMPERATURE:	-25+60 °C	40 HC:	120 units
STANDARD TRAILER:	156 units	MEGA TRAILER:	156 units

DISCLAIMER:

Capacity is dependent on the application and environment of use.
 The suitability of application is to be consulted with Unipas.
 Specifications subject to change without further notice.
 All dimensions approximate.

